



# MAXEN

FIREPLACES

## 150MM FREE STANDING WOOD FIRE FLUE KIT MKIII INSTALLATION INSTRUCTIONS

**WARNING:** THIS FLUE KIT HAS BEEN MANUFACTURED IN ACCORDANCE WITH AS/NZS 2918:2001 AND TESTED TO APPENDIX F. TO ENSURE SAFETY THIS FLUE KIT MUST BE INSTALLED AS OUTLINED IN THESE INSTRUCTIONS AND THE APPROPRIATE REQUIREMENTS OF THE RELEVANT BUILDING CODE OR CODES. WOOD FIRE AND FLUE CLEARANCES FROM THE COMBUSTIBLE WALLS MUST BE IN ACCORDANCE WITH WOOD FIRE MANUFACTURER'S SPECIFICATIONS AND AS/NZS 2918:2001. THESE INSTALLATION INSTRUCTIONS ARE FOR TESTED APPLIANCES ONLY.

**CAUTION:** MIXING FLUE SYSTEM COMPONENTS FROM DIFFERENT SOURCES OR MODIFYING THE DIMENSIONAL SPECIFICATION OF COMPONENTS MAY RESULT IN HAZARDOUS CONDITIONS. WHERE SUCH ACTION IS CONSIDERED, THE MANUFACTURER SHOULD BE CONSULTED IN THE FIRST INSTANCE.

**CAUTION:** IT IS THE RESPONSIBILITY OF THE INSTALLER TO ENSURE THAT THE INSTALLATION OF THIS FLUE KIT COMPLIES WITH AS/NZS 2918:2001, THE APPLIANCE MANUFACTURERS SPECIFICATIONS FOR FLUE PIPE SHIELD AND CEILING PLATE AND THAT THE RELEVANT BUILDING CODES ARE ADHERED TO. BENDS AND EXTENSIONS TO THE LENGTH OF A FLUE SYSTEM ARE PERMITTED (AS/NZS 2918:2001 4.1).

### FLAT CEILING INSTALLATION

- 1) Locate the wood fire in its proposed position and mark a point on the ceiling that is directly above the centre of the flue spigot. Check that the location of the wood fire allows the OUTER GALV LINER to clear all structural roof timbers.
- 2) Cut a 250mm square hole in the ceiling. Directly above cut a hole in roof to accommodate OUTER GALV LINER.
- 3) Fit a timber frame around the ceiling. i.e. frames form a 250mm square aperture that allows air to circulate freely over the OUTER GALV LINER surface.
- 4) Position the OUTER GALV LINER so that it is flush with the underneath of the ceiling and protrudes through the roof at the required height. Note that AS/NZS 2918:2001 4.9 1(a) states, "the FLUE PIPE shall extend no less than 4.6m above the top of the floor protector". **Refer to diagram A.**
  - a) If the FLUE PIPE is within 3 metres of the ridge, the FLUE PIPE must protrude at least 600mm above the ridge of the roof.
  - b) If the distance from the ridge is more than 3 metres, the FLUE PIPE must protrude at least 1000mm above roof penetration.
  - c) The FLUE PIPE must be more than 3 metres from any nearby structure. **Refer to diagram D.**

Additional FLUE PIPE, OUTER GALV LINER and/or INNER GALV LINER may have to be added to ensure the following:

- i) The correct minimum roof penetration height.
- ii) Sufficient overall height to encase the FLUE PIPE which must extend a minimum of 4.6m from the floor protector.

**Refer diagram A.**

*Note that the 200mm INNER GALV LINER should extend to be the same overall length as the 250mm OUTER LINER and terminate at the flue cowl.*

**NB: Do not secure the OUTER GALV LINER SLIP EXTENSION onto the OUTER GALV LINER, as final adjustment will be required when fitting COWL assembly. (See 11).**



# MAXEN

## FIREPLACES

- 5) Fix an appropriate flashing around the OUTER GALV LINER to seal onto the roofing material. Refer to the manufacturer's recommendations for the correct fitting.

**NB: On iron roofs, fixings such as metal angle brackets (40mm x 40mm) can be fitted under the flashing to securely fix the roof to OUTER GALV LINER (supplied).**

- 6) Place the CEILING PLATE over the wood fire's flue spigot, ensuring the folded edges are facing the ceiling.
- 7) Position the bottom length of the FLUE PIPE (crimped end downwards) into wood fire flue spigot. Fit the flue shield spigot bracket between the lower FLUE PIPE and the spigot (rear of Spigot)

**Refer to the supplier of the wood fire and use flue pipe sealant if recommended.**

- 8) Assemble the FLUE PIPES together ensuring seams are not directly in line with each other, as offsetting the seams will ensure a neat fit. FLUE PIPES must be assembled with crimped ends down (towards wood fire). Secure each joint with a minimum of three Monel Steel rivets equally spaced around the joint. The protective wrapping should be left on the FLUE PIPE during installation.
- 9) From the roof lower the FLUE PIPE through the INNER and OUTER GALV LINER into the bottom FLUE PIPE securing with three Monel rivets at each joint.
- 10) Check the FLUE PIPE SPACING BRACKETS inside the INNER GALV LINER are correctly positioned and then from the roof slide, the INNER GALV LINER into the OUTER GALV LINER until the brackets rest on to the internal swage ring of the OUTER GALV LINER, this will ensure the INNER GALV LINER is the correct 12mm above ceiling level.
- 11) Before securing the OUTER GALV LINER SLIP EXTENSION to the OUTER GALV LINER, ensure the FLUE PIPE extends above the top of the INNER and OUTER GALV LINER SLIP EXTENSION by 145mm. Adjust SLIP EXTENSION and trim the inner liner to obtain the measurement.
- 12) Fit TOP SPACER BRACKET to the FLUE PIPE making sure the lugs fit snugly inside the INNER LINER and OUTER GALV LINER SLIP EXTENSION. Make sure TOP SPACER BRACKET fits hard down onto the INNER LINER and OUTER GALV LINER SLIP EXTENSION.
- 13) Fit the GALV LINER COVER over the FLUE PIPE and push down firmly onto TOP SPACER BRACKET.
- 14) Fit the COWL but do not secure, as removal for flue cleaning will be necessary. Deform the stub of the COWL to ensure it is a tight friction fit.
- 15) Fasten the CEILING PLATE to the ceiling using the screws provided. Do not over-tighten, as a 12mm air gap must be maintained via the 4 external slots. Ensure an even air gap around FLUE PIPE when fixing. Remove the protective plastic from CEILING PLATE.

# FLUE SHIELD ASSEMBLY INSTRUCTIONS

Components used are the flue shield, lower shield bracket (fig 1) and the top shield bracket (fig 2).

The lower shield bracket fits between the flue spigot of the fire and the flue pipe (fig 3).



Figure 1.



Figure 2.

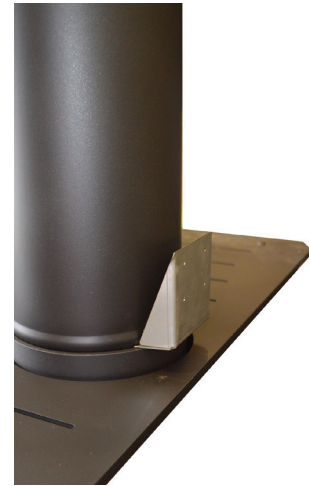

Figure 3.

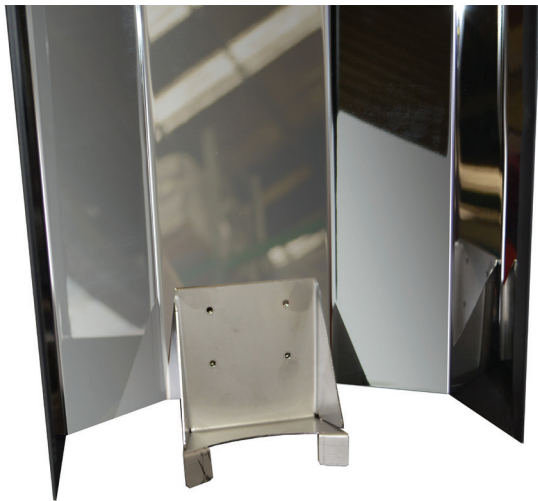

Figure 4.



Figure 5.

The height between the bottom of the flue shield & the top of the heater is referred to on page 2 of the specification sheet for each model. Please check carefully before riveting the lower bracket (fig 4) to the shield to ensure the correct height is reached. A series of holes are pre-drilled in the inner shield. Once the lower bracket is fitted between the spigot and flue pipe, the top bracket (fig 5) can be riveted to the shield and flue pipe.



# MAXEN

FIREPLACES

## SLOPING CEILING INSTALLATION

**The instructions for a sloping ceiling and a flat ceiling are the same except for the following:**

- A) The 200mm Inner Liner, and the 250mm Outer Liner will need to be trimmed to the angle required to suit the ceiling (between 15-45 degrees).
- B) Fitted to the non swaged end of the 200mm Inner Liner are 3 x locating brackets. These will need to be removed and not used.
- C) A 150mm-200mm, and a 200mm-250mm spider bracket will be needed at the ceiling end of the liners.
- D) Point 10) will differ from the flat ceiling installation, in that the 200mm Inner Liner will need to be 6mm lower than the 250mm Outer Liner as shown in Diagram C.
- E) Ensure the 150mm-200 spider is secured to the flue pipe, and is free floating inside the 200mm Inner Liner.
- F) The 200mm-250mm spider must be secured to both the 200mm Inner and 250mm Outer Liners once they have been aligned and the 6mm height difference has been achieved.
- G) Point 15) will also differ from the flat ceiling installation as the sloping ceiling plate will use ceramic spacers between the ceiling plate and ceiling. Please do not over tighten the screws.



# DIAGRAM A

## 150mm Free Standing Flue Kit Satin Black, 4.2 Metres MKIII

(Kit Code: 902251)

Manufactured by Escea Limited.

This flue kit must be installed by a suitably qualified tradesperson or solid fuel heater installer and complies with AS/NZS 2918:2001. This kit may require additional components to complete the installation

### ROOF AND CEILING INSTALLATION

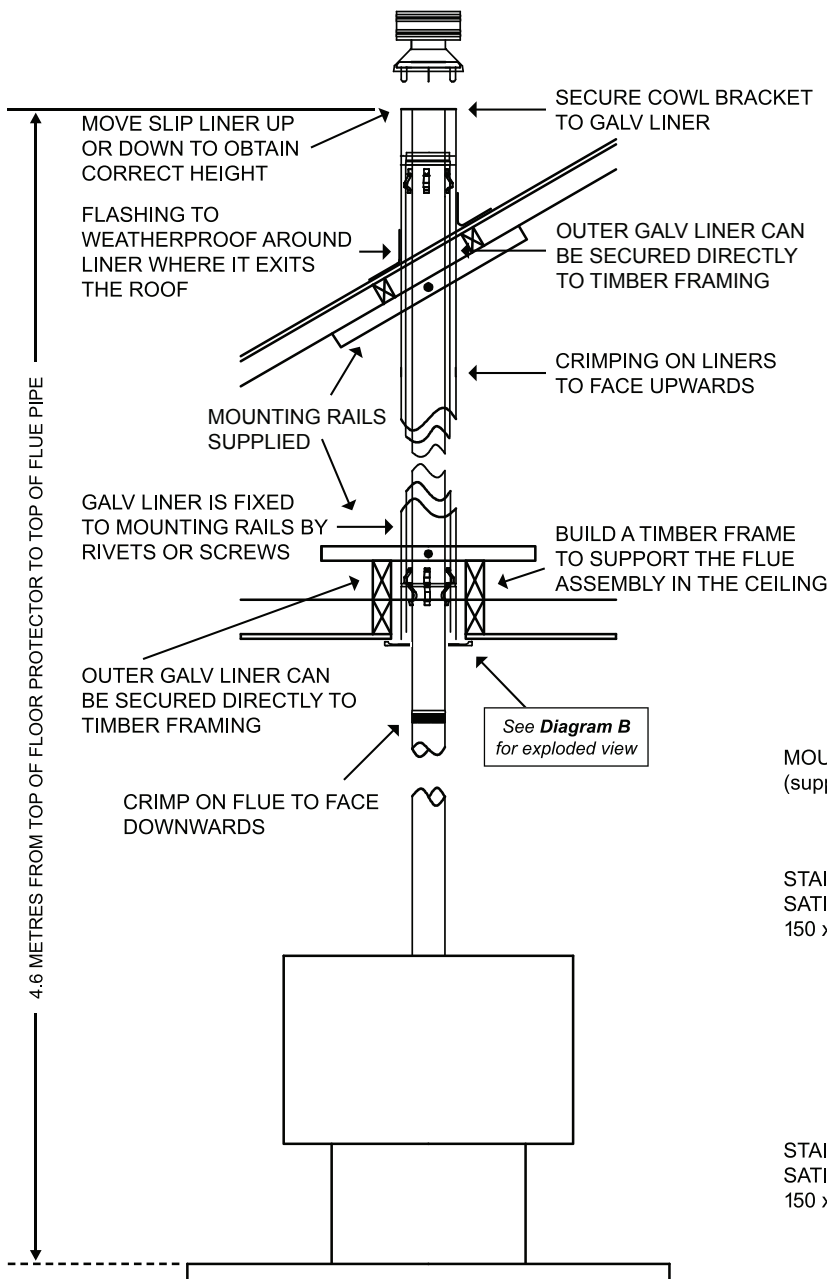

### ASSEMBLY LIST

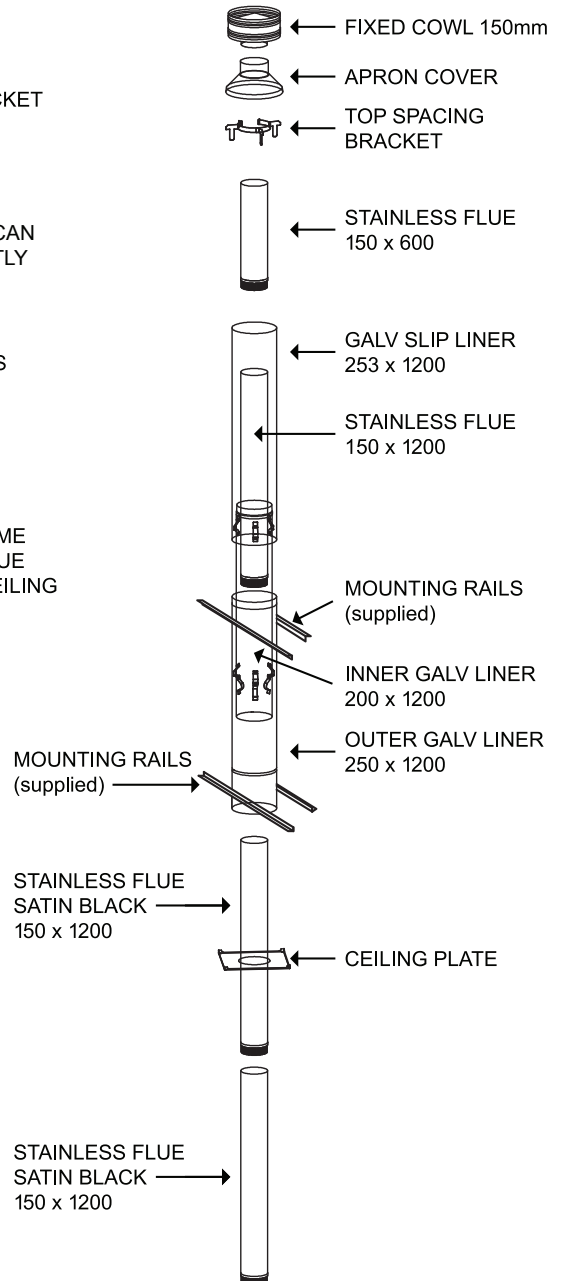
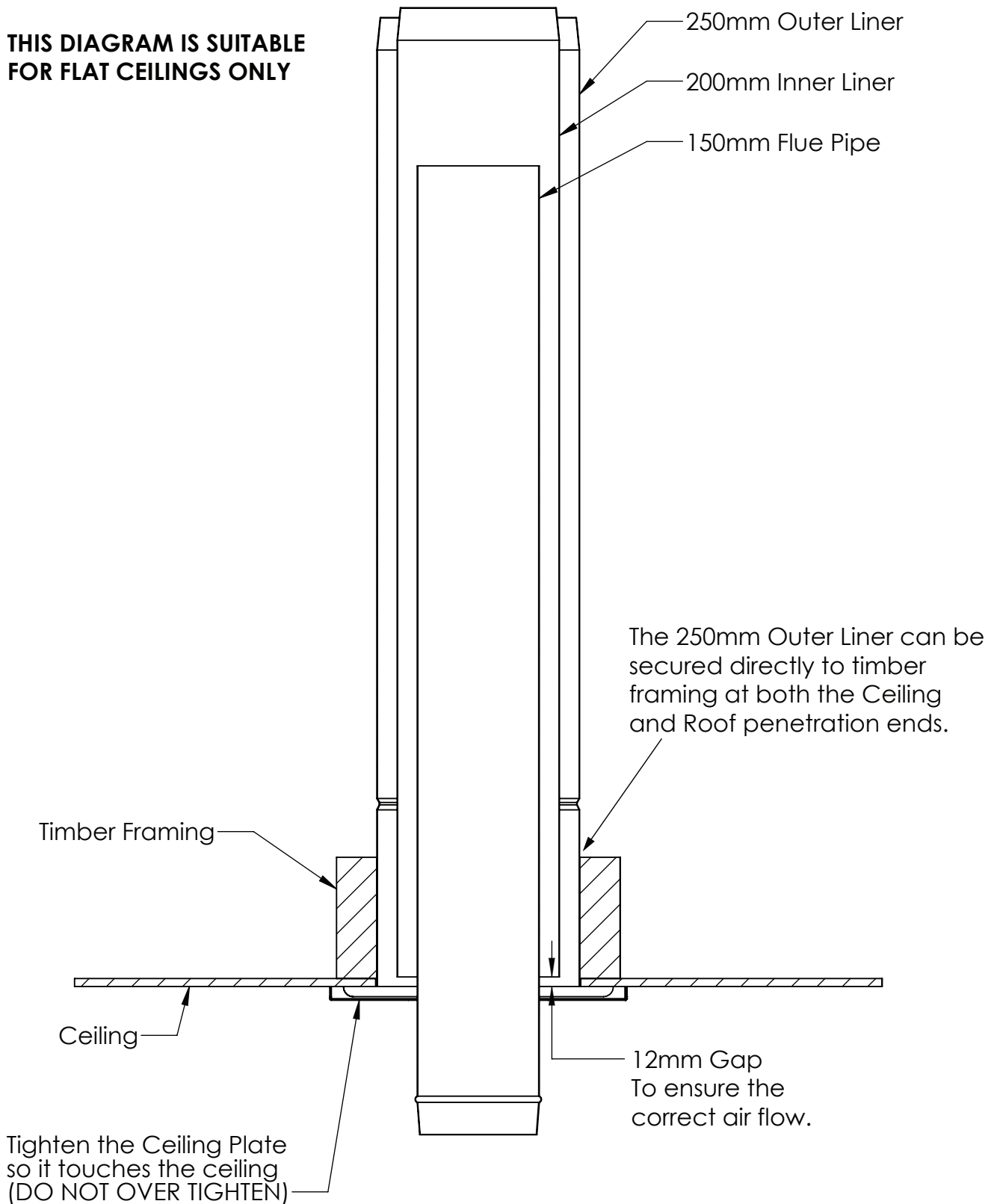



**DIAGRAM B**

**POSITIONING LINERS AND CEILING PLATE**

**THIS DIAGRAM IS SUITABLE  
FOR FLAT CEILINGS ONLY**





# DIAGRAM C

## POSITIONING LINERS AND CEILING PLATE

This diagram is suitable for sloping ceilings 15-45 degrees

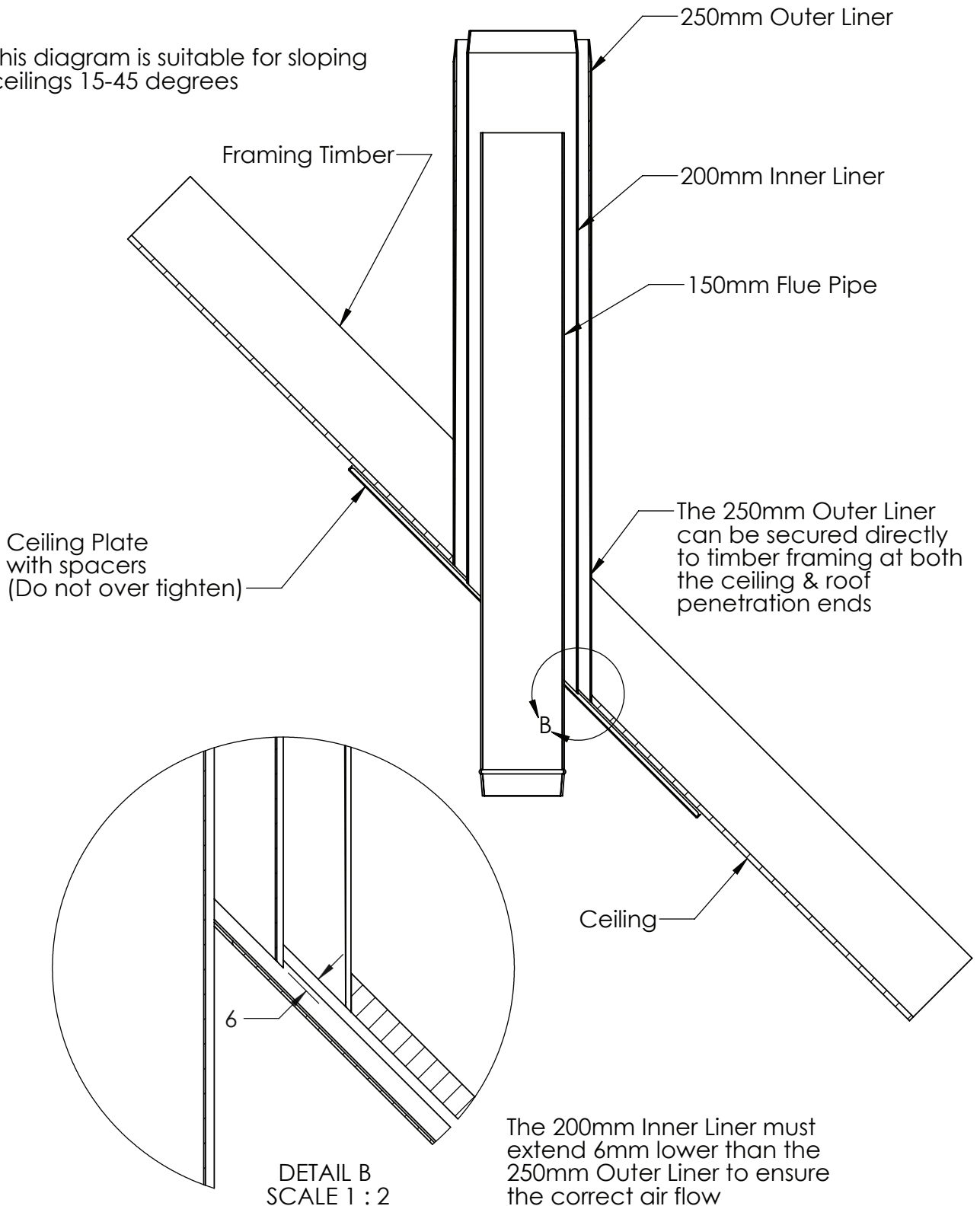



# DIAGRAM D – AS/NZS 2918:2001

## MINIMUM HEIGHTS FOR FLUE SYSTEM

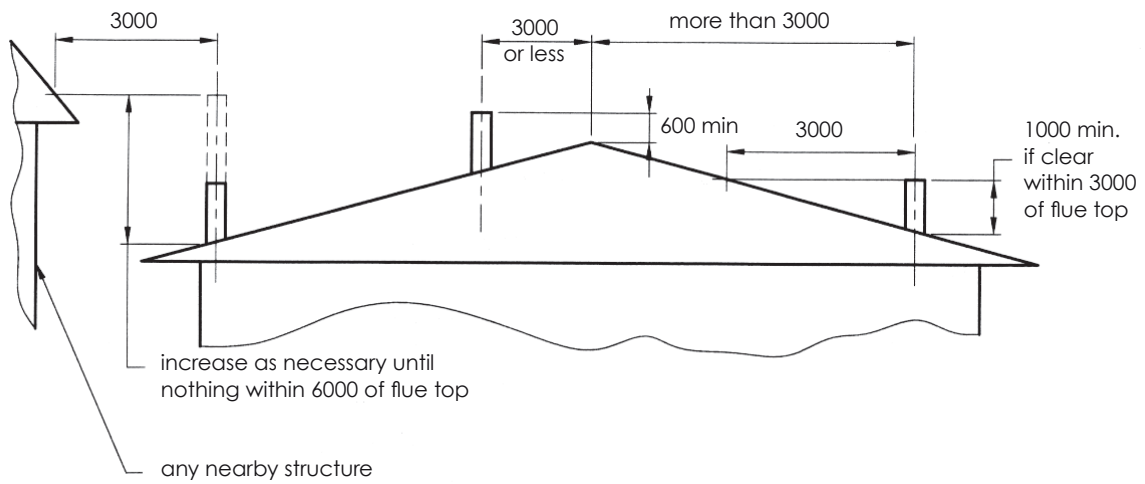
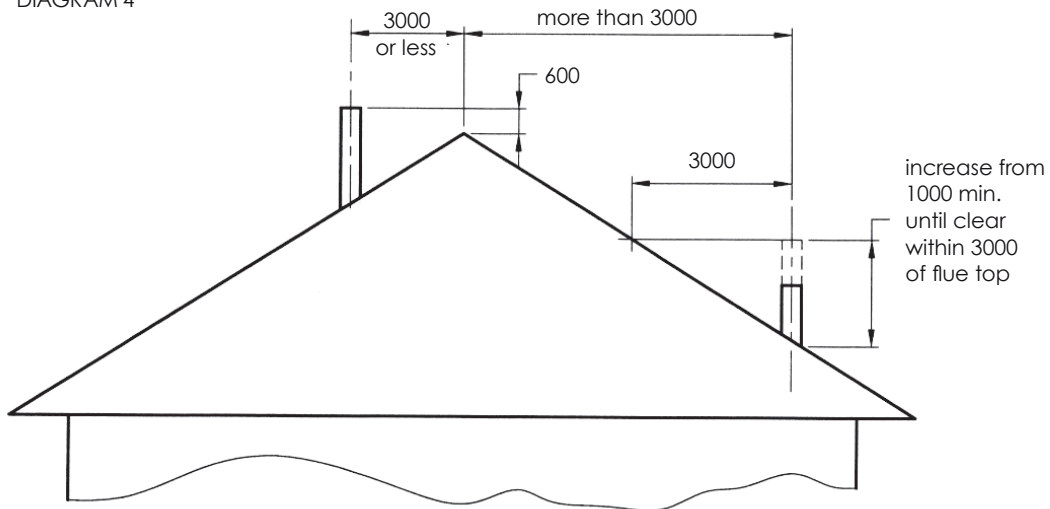

DIAGRAM 4



**Notes:**

Depending on local circumstances, taller chimneys may be required for satisfactory performance, check with your local retailer or installation technician.



# DIAGRAM OF 45° CEILING PLATE

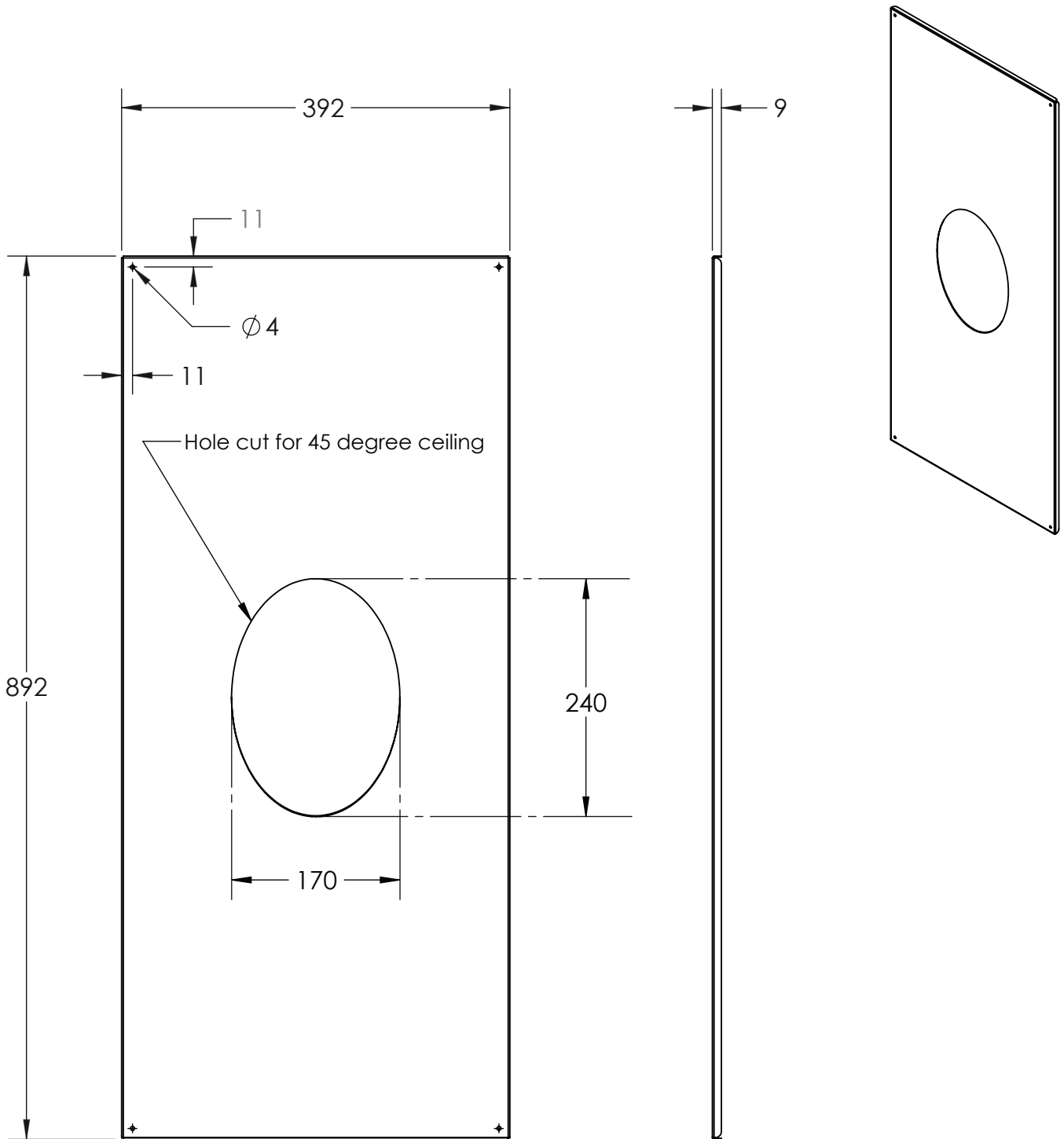

Ceiling Plate required as tested



# MAXEN

FIREPLACES

## FLUE KIT BLACK 4.2M MKIII

### **Contents Include:**

- 2 x Flue Stainless Steel 150 x 1200mm (Black)
- 1 x Flue Stainless Steel 150 x 1200mm
- 1 x Flue Stainless Steel 150 x 600mm
- 1 x Flue Galvanised Liner Combination (Inner: 200 x 1200mm / Outer: 250 x 1200mm)
- 1 x Flue Outer Galvanised Liner Slip Extension 253 x 1200mm
- 1 x Anti Down-Draught Cowl 150mm
- 1 x Apron Cover 150-250mm
- 1 x Ceiling Plate 150mm (Black) 370mm Square
- 1 x Ceiling Plate Screw Pack (4)
- 1 x Top Spacing Bracket, Bolt and Nut
- 2 x 40 x 40 x 1200mm Galvanised Mounting Rails
- 1 x Double Flue Shield MKIII
- 1 x Top Flue Shield Bracket
- 1 x Bottom Flue Shield Bracket (Multi-fit)

### **OPTIONAL COMPONENTS FOR A SLOPING CEILING (NOT SUPPLIED IN KIT)**

1X polished SS ceiling plate at 45°, 30°, or 15°

1X white ceiling plate at 45°, 30°, or 15°

1X black ceiling plate at 45°, 30°, or 15°

1X pack (4) ceramic ceiling plate spacers

1X 150mm - 200mm spider bracket

1X 200mm - 250mm spider bracket