



**MAXEN**

FIREPLACES

**Cargill 350  
ULTRA LOW EMISSION  
BURNER**

INSTALLATION AND OPERATING INSTRUCTIONS

*Please leave this information with the appliance*



SEE INSIDE TO REGISTER  
FOR YOUR 15 YEAR WARRANTY.

# ***Congratulations on the purchase of your Maxen wood fire.***

*Please read this installation and operation manual carefully.*

*The installation of this fire must comply with the Installation Standard AS/NZS 2918:2001 as well as any additional local requirements.*

*Please ensure you have all relevant permits prior to installation.*

*Keep this booklet as a reference guide.*

## **INSTALLATION OF YOUR MAXEN WOOD FIRE**

Maxen recommends you use a suitably qualified installation technician to install your fire. Your dealer or heating specialist will be able to help with recommendations as well as advise on permits/consents required for the installation in your area. Web address for NZHHA certified installers/service person. [www.nzhha.co.nz/find-a-member/](http://www.nzhha.co.nz/find-a-member/)

Our fireplaces have been lab tested in a standard 4.2m flue installation. If your installation requires additional flue lengths (ie. multi-storey installations) its important to note that each additional length will increase the amount of flue draw.

Please follow carefully all dimensions and recommendations provided on the individual specification sheet for your model of heater as these dimensions comply with the required New Zealand standard (AS/NZS 2918:2001).

***As safety and emissions performance can be affected by altering the appliance, no modifications are allowed without the written permission from the manufacturer.***

As all solid fuel appliance installations are unique, we provide lab tested specifications based upon a standard installation (ie. single storey, 4.2m height and 2.4m ceiling height etc).

In the event the installation of your appliance varies from the tested nature of these fires, it's important to ensure that any variations are compliant with the relevant safety standard for solid fuel installations AS/NZS2918:2001 - this standard can be purchased through Standards New Zealand or your professional fire installer will have a copy.

As each installation is unique and can be impacted by operating and environmental factors, Maxen's support team are not qualified to provide technical advice in relation to achieving compliance outside of lab tested applications.

For any inquiries related to variations from a standard install (as described in the manufacturers spec sheet and install instructions), we strongly recommend consulting your local NZHHA (New Zealand Home Heating Association) accredited installer for specific advice relative to your site and situation.

Accredited installers not only ensure that your fire will be compliant and signed off by councils but also have the skills to advise on any custom requirements that will overcome typical installation issues such as environmental conditions, poor installation design, negative pressure and other factors which can lead to poor performance.

## INSTALLATION

1. Unpack the heater and check that there is no damage, if the product is damaged do not proceed with the installation - please contact your retailer.
2. Ascertain the position of the roof penetration for the flue system.  
A correctly installed flue system will normally prevent down draught problems during windy weather and eliminate smoke spillage problems due to lack of draught.
3. Ascertain suitable position for appliance and size of floor protector and check the ceiling to ensure that no major structural members will be affected by the path of the flue.
4. Check that the sub-structure is capable of carrying the heater (i.e. weight consideration on the floor).
5. Check measurements of the heater to combustibles or shield.
6. Locate the heater in the required position (also see 'Fitting Seismic Restraint' after installation instruction #10).
7. Using a plumb line fastened to the ceiling, mark the centre of the flue penetration position and cut the ceiling hole to the required size and frame out.
8. Install the flue system (see flue installation instructions supplied with flue system).

### Remember:

- The flue system should rise vertically from the appliance with as few offsets as possible. Offsets should be limited as each change in direction creates a resistance to airflow and makes flue cleaning difficult.
- The flue system must be well sealed with a minimum of 3 fixings at each joint. We recommend using flue sealant on all joints.
- The flue pipe penetrating the chimney must continue to the minimum length of 4.6m from the top of the floor protector to the cowl.
- Flue exiting more than 3 metres from the ridgeline must terminate no less than 1 metre above the roof penetration (see diagram 1 below).
- Where the top of the flue pipe is more than 2 metres above its highest fixing point, it must be stayed against high winds.

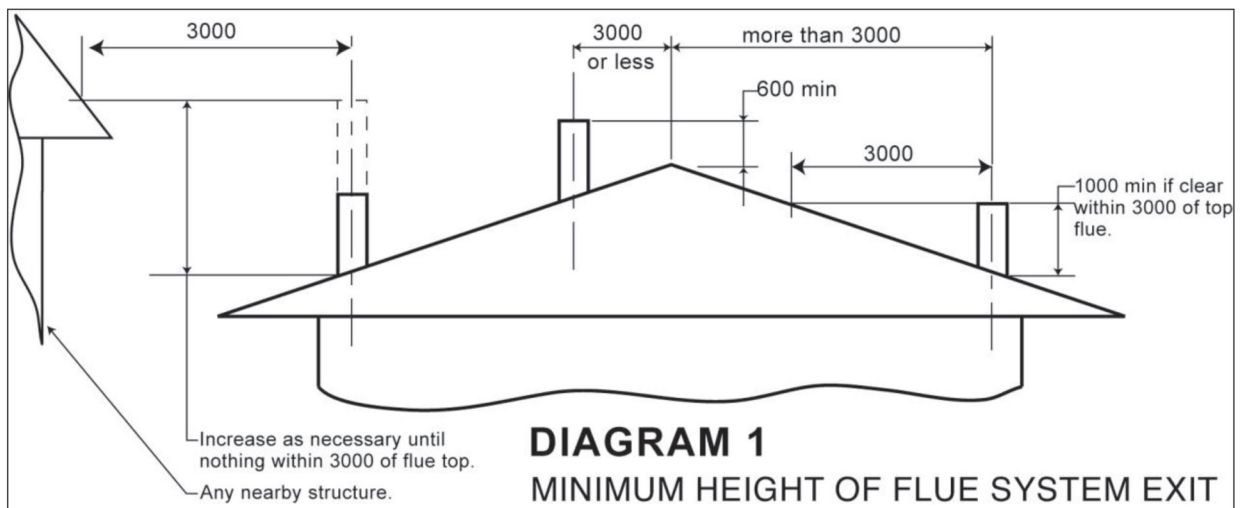

9. Drill and fix flue system into flue spigot with stainless steel self-tapping screws.
10. Drill and secure the appliance to the floor protector using the two holes in the rear base of the appliance.

11. (applicable for external air ducted appliances only) If external air is preferred or required for your installation, Install semi rigid or rigid ducting from the 100mm spigot on the rear of the appliance though an external wall or floor. • External penetrations will likely require weather resistant cowls or grills installed. • Wrapping/flashing of duct work shall be installed in line with applicable building regulations. • Minimum of 100mm diameter cross section duct should be used where possible and for extended duct lengths. • For short duct lengths, duct transitions, grills etc require a minimum duct cross section of 4200mm<sup>2</sup> to be maintained. • Rodent mesh should be utilised where required.

### **FITTING SEISMIC RESTRAINT**

The Floor Protector must be mechanically fixed to the floor by bolting or screwing. **Note:** *Floor Protector to be fixed by gluing when on a concrete floor that may have water pipes or electrical wires present. The appliance can then be bolted to the floor protector with two 6mm x 50mm dynabolts.*

### **EXTERNAL AIR CAPABLE APPLIANCES**

Appliances equipped with external air capabilities have the option to duct air used for combustion within the fire box from outside the building rather than within the room the fire is installed. This feature may be particularly beneficial when the appliance are installed within a room/space with a range hood (that creates a negative pressure within the room) and in modern homes which typically are well sealed which may result in a negative pressure within the room during fire operation. A lower pressure within the room than the fire box can be particularly problematic when reloading fuel into the appliance as additional smoke will likely be draw out of the fire box and into the surrounding room if a pressure differential exists.

### **BAFFLE**

Before lighting your appliance for the first time, make sure the baffle is in the correct position being as far to the rear as possible, and ensure all packing material has been removed.

### **REDUCING CLEARANCES TO COMBUSTIBLE WALLS**

In the event it is necessary to reduce the clearances to combustibile surfaces, it must always be done in accordance with the safety standard AS/NZS2918:2001 Section 3, Tables 3.1 and 3.2

The shielding shall be constructed from a heat resistant material. The shield must be fixed to the surface that requires protection and NOT the heater.

The standard allows three options to reduce the stated clearances:

Single Layer of continuous material with minimum Air Gap of 12mm to achieve a clearance factor of 0.40

Single layer of continuous material with minimum Air Gap of 25mm to achieve a clearance factor of 0.30

Two spaced Layers of continuous material with minimum Air Gap of 12mm + 12mm to achieve a clearance factor of 0.20

The shielding must be open at the top and bottom (vented) to allow a continuous air flow. It is this flow that keeps the surface requiring protection cool. Fixings should not impede this air flow.

The shielding needs to go far enough along and up the wall so that the original side and rear required clearances are not compromised. As the flue is now closer to the wall the shielding should also protect the wall from the flue pipe.

**Example:**

- Side wall clearance for the Maxen Kinmont 350 is 290mm
- A 12mm gapped shield on the wall with a factor of 0.40
- Calculate:  $290\text{mm} \times 0.40 = 116\text{mm}$  (This is the new sidewall minimum clearance)
- The shielding needs to be large enough that none of the original clearances of 290mm are compromised.

## **WATER BOOSTER - APPLICABLE INSTALLATIONS**

A Maxen Water Booster must be fitted by a Certified Plumber to a low pressure open vented water storage system, or an indirect system (heat exchanger). Please check with your Certified Plumber.

For optimum performance, your cylinder should be no more than four metres from the fire. The distance should be kept to a minimum. A 1 in 12 minimum rise is recommended for the hot water return pipe. The pipe work must be 25mm diameter and should avoid sharp bends or restrictions.

**PLEASE NOTE** - When using a Water Booster fitted to an existing, or new cylinder, a Tempering Valve must be fitted to limit hot water temperature to the users, as per the Building Code.

**PLEASE NOTE** - Water booster instructions are shipped with the booster.

### **WARNINGS**

- 1. WARNING:** THE HEATER AND FLUE SYSTEM SHALL BE INSTALLED IN ACCORDANCE WITH AS/NZS 2918:2001 AND THE APPROPRIATE REQUIREMENTS OF THE RELEVANT BUILDING CODE OR CODES.
- 2. WARNING:** APPLIANCES INSTALLED IN ACCORDANCE WITH THIS STANDARD SHALL COMPLY WITH THE REQUIREMENTS OF AS/NZS 4013 WHERE REQUIRED BY THE REGULATORY AUTHORITY, I.E. THE APPLIANCE SHALL BE IDENTIFIABLE BY A COMPLIANCE PLATE WITH THE MARKING 'TESTED TO AS/NZS 4013. ANY MODIFICATION OF THE HEATER THAT HAS NOT BEEN APPROVED IN WRITING BY THE TESTING AUTHORITY IS CONSIDERED TO BE IN BREACH OF THE APPROVAL GRANTED FOR COMPLIANCE WITH AS/NZS 4013.
- 3. WARNING:** PLEASE ENSURE THAT ONLY COMPONENTS APPROVED BY MAXEN ARE USED FOR THE INSTALLATION AS SUBSTITUTES MAY ADVERSELY AFFECT PERFORMANCE AND MIGHT NULLIFY COMPLIANCE WITH THE REQUIREMENTS OF AS/NZS 2918:2001.  
**CAUTION:** MIXING OF HEATER OR FLUE SYSTEM COMPONENTS FROM DIFFERENT SOURCES OR MODIFYING THE DIMENSIONAL SPECIFICATION OF COMPONENTS MAY RESULT IN HAZARDOUS CONDITIONS. WHERE SUCH ACTION IS CONSIDERED, THE MANUFACTURER SHOULD BE CONSULTED IN THE FIRST INSTANCE.
- 4. CAUTION:** CRACKED AND BROKEN COMPONENTS, E.G. GLASS PANELS OR CERAMIC BRICKS MAY RENDER THE INSTALLATION UNSAFE.

# CORRECT OPERATION OF YOUR MAXEN CARGILL 350 WOOD FIRE

## 1. YOU WILL NEED

- 1kg of kindling (Approximately 16 pieces)
- 4x pieces of small sized wood (approx 1.2kg in total - Intermediate Load 1)
- 4x pieces of medium sized wood (approx 2.5kg in total - Intermediate Load 2)
- 2x Natural Firelighters
- 1x Lighter (Long reach lighter recommended)

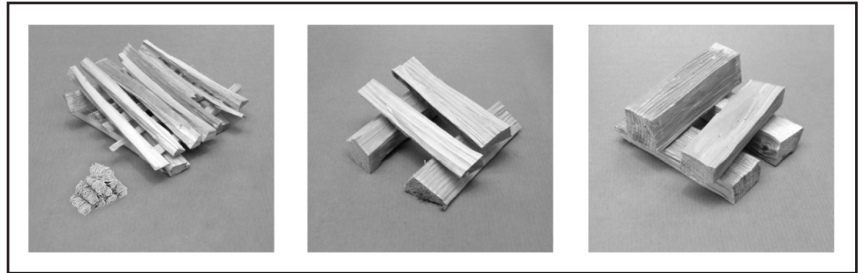

## 2. LOADING THE FUEL AND LIGHTING

Intermediate Load 1 is laid across the base of the firebox in a front to back arrangement. The kindling is then cross stacked on top of the first Intermediate load and the firelighters are placed in the top row of the kindling stack (as shown). Light the firelighters; then close and lock the door.



## 3. ADDING THE SECOND INTERMEDIATE LOAD

Once most of the kindling has burnt to embers, place the second intermediate load onto the embers as pictured and close the door.



## 4. ADDING FURTHER LOADS

Once the flames have disappeared and red embers remain, it is time to load the main load (3 pieces at approx 3kg in total). Load the fuel onto the embers as pictured and close the door.



## ADDITIONAL TIPS

The primary air control can be adjusted to increase or decrease the amount of air entering your fire. The more air entering your fire the hotter and faster it will burn. Adjust the primary air control and quantity of pieces of fuel loaded to increase or decrease the heat output of the fire.

Turn the primary air control to high when loading new fuel to help the fuel ignite and reduce emissions. Once the fuel is alight and has a blackened appearance on the surface the primary air can be turned to low if a longer, lower heat output burn is desired.

Always open the fire door slowly to allow fresh air to enter and maintain the smoke path. If you open the door too quickly or during the ignition phase while the fire is warming up, smoke can puff out.

**Preventing creosote build-up:** Creosote is a tar-like substance that builds up when the organic compounds in smoke condense onto cooler flue surfaces. Left to build up over time, creosote will restrict the airflow of the flue and impair the performance of your heater. The production of smoke is at its highest when a fresh fuel load is added or when the air control is at its lowest position. The most effective way to control the creosote formation is to burn the heater so as to ensure as complete combustion as possible and at the same time promoting higher flue temperatures. Smoldering fires should always be avoided.

The amount of charcoal in the ash is often a good indicator of how well you are operating the heater. If there is no charcoal and only very fine ash, then you are doing an excellent job. If there is a lot of charcoal you may be turning the combustion air down too soon after refuelling, or not raking the charcoal to the combustion air inlet, or turning the combustion air down too low to support efficient combustion, or all of the above.

### ***REMEMBER: THE HOTTER THE FIRE, THE LESS CREOSOTE FORMATION.***

When you have mastered the techniques for efficient wood burning, here is what you should see:

1. When wood burns it should be flaming until only charcoal remains. If there are no flames, something is wrong.
2. Firebricks in the firebox should be tan in colour, never black.
3. Steel parts in the firebox should be light to dark brown, never black and shiny.
4. With seasoned wood, correct air settings and proper loading arrangement you should expect quick ignition of a new load of wood - the bottom pieces should be flaming by the time the door is closed.
5. The glass door should be clear. A discoloured glass indicates that the wood is too wet or the air control has not been left open long enough.
6. The exhaust coming from the top of the flue system should be clear or white. A plume of blue or grey smoke indicates smoldering, inefficient combustion, air pollution and probably low operating temperatures.

Correctly installed and operated, Maxen solid fuel heaters do not spill smoke into the house. There are three main reasons why some woodstoves smoke:

**Bad installation design:** Incorrect flue installation, resulting in low flue temperatures and low draught, can make a wood heater more likely to spill smoke. For example, flue systems that run up the outside wall of the house and are not correctly insulated can rob the heat from the flue and produce very little draught. Each elbow in the flue pipe assembly slows down the flow of gases and causes a small restriction to flow. When a flue system includes more than one elbow, the restriction can be enough to cause spillage.

In some non-standard installations such as two storey homes flue extensions may be required. Please consult with your installer on how extending the flue will impact the flue draw rate, expected burn times and any special installation requirements. Please note, extended flue lengths commonly produce greater flue draft which may result in the appliance burning harder. It is advised that the air control be adjusted to the low setting during periods of prolonged use to maintain the life of the appliance.

**Extreme negative pressure in the house:** Energy efficiency practices and new building code rules are making our houses more and more airtight. This makes the houses energy efficient, but also makes them more sensitive to negative pressure when air is exhausted from the house. Large, fan-forced exhaust ventilators, like down-draught-type kitchen stove exhausts, can cause extreme negative pressure in the house when they are operating. Because new houses are tightly sealed, there are few holes to allow replacement air to enter, and the house pressure becomes negative. This negative pressure works against flue system draught. In severe cases, the negative pressure in the house overcomes the flue system draught and the appliance begins to spill smoke, especially when a fire is started or when it dies down to coals. To prevent this extreme negative pressure, one option is to open a window slightly to allow combustion air into the room. Another option is to avoid using extractor fans during fire start up and rekindling phases of operation.

**Improper heater firing technique:** When a solid fuel heater is starved for air it smoulders, producing a relatively cool, smoky fire. The temperatures throughout the system are low. During a smouldering fire, the flue system will not be receiving the hot gas it needs to produce strong draught. When the heater door is opened, smoke will spill into the room. A smouldering fire is the single most common reason for smoke spillage and totally unnecessary. By using the suggestions on proper firing technique earlier in this document, you will be able to avoid these smouldering fires.

## **PURCHASING THE FIREWOOD**

The quality of the firewood you burn can have a dramatic effect on the efficiency and operation of the heater. The main factors that affect the burning characteristics of firewood are moisture content, tree species and piece size.

The moisture content of the wood affects the rate at which it burns and the efficiency of combustion. When trees are cut, the wood moisture content ranges between 35 and 60 per cent by weight. If you attempt to burn wood this wet it will be hard to ignite, slow to burn and will hiss and sizzle in the firebox. So much energy will be consumed in boiling off the excess water that the efficiency of combustion and the heat to your home will be low, condensation and corrosion may be occurring in the flue and smoke may be causing problems to your neighbours. Properly seasoned wood ignites readily and burns efficiently.

**PLEASE NOTE: WOOD WITH A MOISTURE CONTENT OF 10-25% IS THE RECOMMENDED WOOD TO USE IN CLEAN AIR ZONES**

**Kiln dried fuel (less than 10%) will not burn for as long as seasoned wood.**

**Firewood should be cut and split in the early spring and stacked under cover, with good ventilation, to be ready for burning when required.**

Look for checks or cracks in the end grain as a sign of dry wood. The stacks of firewood should be in an open area so that air can circulate through them. During the summer, as warm breezes flow through the stacks, carrying away the evaporating water, the moisture content of the wood will fall to around 20 per cent. At this moisture content the wood is ready for burning.



Although the energy content of dry wood per kilogram is almost the same regardless of species, some burn differently because of differences in density e.g pine is less dense than woods like gums, Manuka or Black Wattle. A denser wood will produce a longer-lasting coal bed, while a less dense wood will bring a fire to an optimum burning temperature more quickly.

The size of the firewood pieces affects the rate of combustion. Larger pieces ignite and release their energy more slowly than small pieces. Smaller pieces are better for short, hot fires and larger pieces are preferable for extended firing cycles. In general, commercial firewood dealers supply firewood in thicker pieces than modern wood-burning heaters can handle. It is often necessary to split some of the wood again before using it. The thickest piece size for high-efficiency heaters should not exceed about 150mm (6 in.) across the largest dimension and a range of smaller pieces will be needed for effective stoking. Maximum log length varies according to model.

## **BURNING COAL**

Due to their construction, the burning of coal in Maxen solid fuel heaters is prohibited. Please also refer to 'Exclusions' in the Warranty Page 14.

## **MAXEN WOOD FIRE MAINTENANCE**

To keep your fire burning clean and efficient it is important that you carry out regular maintenance. General maintenance checks should include the following:-

### **ASH DRAWER TECHNIQUE**

If your fire is equipped with the ash drawer feature, this makes cleaning your fire quick and simple. Once the fire is cold; use your fire poker tool to lift the plug out from the base of the firebox. Sweep the ash remnants down the hole and into the ashbox below. Attempt to retain an ash bed of 30-40mm in your firebox (this retains heat, prolongs the life of your firebox, and assists in getting your fire up to operating temperature faster). After lifting the ashbox out of the drawer, close the top cover on the ashbox to avoid spillage while emptying the ashes.

Once you've cleaned your ashbox, ensure the sliding rails of the drawer are free of debris. Replace the ashbox into the drawer, making sure the lid is in the open position and the ashbox is pushed toward the rear of the drawer. Close the drawer, clean, then re-fit the plug into the base of the firebox. It is important that the plug does not leak any air after re-fitting, so be sure to sweep any debris down to the ash box before replacing the ash bung flush in the base of the firebox. Any foreign matter which prevents the bung sealing the firebox may lead to uncontrolled air entering the firebox and cause over-firing. Always keep the ashbox and drawer correctly in place while operating your wood fire.

**ASH REMOVAL** - Due to the high efficiency of your Maxen fire, ash removal should only be necessary every few weeks. Ashes can be removed easily through the fire door when the fire is at its lowest, such as first thing in the morning, or when it is completely out. Always use a metal container to remove ash from your fire as ash can maintain high temperatures for several days. Maxen fires work best when a small amount of ash (approximately 40mm deep) is left in the firebox after cleaning. This insulates the bottom and prevents the base of the firebox overheating and burning out. In fact, building up the ash bed helps extend the long burn cycle, while reducing the ash bed encourages greater heat output.

**SURFACES** - Maxen wood fires have high temperature painted surfaces which just need wiping to clean when the fire is cold. If rust appears on your fire, it can only occur due to the presence of water or moisture. This can cause the steel to oxidise but can be easily remedied with a light sanding and touch up using the matching paint. The frequency of maintaining the exterior of your fireplace will depend on the frequency of use, age of the appliance, and your personal visual preferences.

**FIREBOX** - Check the firebricks, top baffle and interior surfaces. These parts are subjected to considerably high temperatures and stress and some parts will eventually need replacing.

**DOORS** - Check all gaskets used for wear and replace if necessary. Adjust door fitting if required.

**LUBRICATION** - All moving parts should be lubricated with graphite grease every couple of months.

## **CHIMNEY CLEANING AND CHECKING FLUES**

For all wood fires, flue cleaning must be done regularly to avoid serious flue fires. Frequently used fires should be cleaned at least once a year (some sooner). The cleaning rate, however, depends on the burning habits of the individual operating the wood fire. For example, it is possible to clog a flue in just a few weeks if smouldering fires are burnt and the flue is run cold.

It is recommended that flue sweeping be done by a professional chimney sweep. Chimney sweeping is a specialist task and competent professional sweeps are available throughout the country. When the flue is cleaned it is recommended that other parts, such as baffles, are checked.

Flue systems should be checked at least once a heating season. Flue systems may require checking more often if the fuel or operation of the appliance is incorrect. When a flue system becomes excessively blocked or requires frequent cleaning, advice should be sought to investigate the installation and the operation of the fire. Flue pipes can deteriorate very quickly with incorrect firing.

## **CONSUMABLES**

Some parts of your Maxen fire are considered consumable. They are designed to be replaced as they will degrade over time. The life of the consumables will vary depending on;

- Frequency of use. How often the fire is used
- Rate of burn. Is the fire burning on low or high the majority of the time
- Type of fuel. Some woods are much harsher than others

General items that are considered consumables:

- Baffles
- Fire bricks
- Air tubes
- Glass and door ropes

It is very important that you replace these parts when they show sign of wear. They effect how the fire runs and you may increase your fuel consumption or lower your efficiency if not replaced, and can in some cases, damage the firebox. It is generally obvious once a part is in need of replacement. Steel components may split or large holes may appear, fire bricks may crack and disintegrate. We recommend you check your fire visually several times a year for damaged components. Failure to replace fire parts that have been compromised may impact your firebox warranty.

## **WARNINGS**

Below is a list of warnings to ensure efficient and safe operation of your Maxen wood fire:

- **WARNING:** DO NOT USE FLAMMABLE LIQUIDS OR AEROSOLS TO START OR REKINDLE THE FIRE.
- **WARNING:** DO NOT USE FLAMMABLE LIQUIDS OR AEROSOLS IN THE VICINITY OF THIS APPLIANCE WHEN IT IS OPERATING.
- **WARNING:** DO NOT STORE FUEL WITHIN APPLIANCE INSTALLATION CLEARANCES.
- **WARNING:** OPEN AIR CONTROL BEFORE OPENING FIRE DOOR.
- **WARNING:** THIS APPLIANCE SHOULD NOT BE OPERATED WITH A CRACKED GLASS.
- **WARNING:** THIS APPLIANCE SHOULD BE MAINTAINED AND OPERATED AT ALL TIMES IN ACCORDANCE WITH THESE INSTRUCTIONS.
- **CAUTION:** THE USE OF PRESERVATIVE-TREATED WOOD OR DRIFTWOOD AS A FUEL CAN BE HAZARDOUS.
- **WARNING:** HOT FUEL OR EMBERS CAN FALL OUT OF THE FIRE BOX WHEN REFUELING THE APPLIANCE AND CAN RESULT IN BURNS OR FIRE. CARE SHOULD BE TAKEN WHEN OPENING THE APPLIANCE DOOR DURING OPERATION.
- **WARNING:** APPLIANCES WITH A SPECIFICALLY DESIGNED WOOD STORAGE AREA MAY ONLY HAVE WOOD STORED IN THIS AREA. THE FUEL STORAGE AREA SHOULD NOT BE USED TO STORE ANY OTHER FLAMMABLE ITEMS. THE WOOD SHALL NOT BE STACKED TO A POINT WHERE IT CAN TOUCH THE CEILING OF THE WOOD STORAGE COMPARTMENT.
- **CAUTION:** FAILURE TO REPLACE FIRE PARTS THAT HAVE BEEN COMPROMISED MAY IMPACT YOUR FIREBOX WARRANTY.

## **MAXEN WOOD FIRE WARRANTY**

### **15 YEARS (conditional)**

Congratulations on the purchase of your Maxen Wood fire. You must register your fire by email or post within 30 days of installation to validate the guarantee (this registration card is in your install/operation guide).

Your firebox is guaranteed for domestic application against faults and defects in workmanship for a period of fifteen years (except for door seals, glass, glass seals, fire bricks, secondary air systems and baffle, paint and exterior finishes - which have 12months parts only cover). This firebox cover is subject to proof of annual inspection and servicing by a suitably qualified fire technician.

Your fire must be installed in accordance with the manufacturer's instructions, any relevant bylaws, standards and regulations. Maxen are not responsible for consequential damage by a failure or defect covered in this guarantee. All claims (in the first instance) should be directed to the store of purchase. Any repairs undertaken without the manufacturer's authority will render the guarantee void. Water boosters must be a Maxen model specified with the fire to be covered; this guarantee applies to the original purchaser only.

Any damage caused by mishandling, overfiring, misuse, abuse or alteration is not covered by this guarantee neither is normal wear and tear. Accessories such as flues, non-genuine parts or any third-party service are not covered by this manufacturer guarantee.

In the event of an approved claim; Maxen will complete repairs or replacement (at their discretion) and return the product to the owner. Any claim which can be remedied by on-site repair will be solely at Maxen's discretion and arrangement. Maxen are not responsible for site conditions such as draughts, cleaning or environmental conditions affecting performance.

You will be required to pay a deposit for any site visit; which will be credited back to you if it is a warranty claim.

For easy support on best use, troubleshooting and optional accessories; please see [www.maxenfireplaces.com](http://www.maxenfireplaces.com) for further details and online product registration.

Escea Limited  
PO Box 5277  
Dunedin  
New Zealand

# MAXEN WOOD FIRE - SERVICE REGISTER

## Maxen recommends NZHHA registered service technicians

To ensure many years of performance and safety with your Maxen Fire, we have outlined the key servicing requirements that form part of routine annual servicing. Maintenance of parts that protect your firebox will extend the life of your fire, ensuring it burns clean and correctly. In the event the firebox is not maintained regularly, this will void the warranty and compromise future claims.

Every season following your fire installation, ensure your fire service technician checks the following points and performs a sweep. In the event you need to claim on your warranty; this evidence of your routine servicing will be requested to validate your claim

- sweep the chimney
- check the condition of the fire box
- check or replace the firebricks if necessary
- check combustion plates and replace if necessary
- check and replace air tubes if required
- check and replace glass and door seals if necessary
- check door seal and alter if not sealing correctly
- check installation if necessary, correct length of flue, fallout faults, flashing or other leaks, flue being riveted correctly, flue joins sealed and fixed to appliance, overall operation of appliance with homeowner
- order parts and fit to appliance
- notify homeowner of all findings and invoice accurately for all work carried out

I confirm that the appliance has been checked and repaired to a safe and correct operating standard as per the manufacturer’s best practise recommendations above:

Interval	Service Agent	Signature	Phone	Date
1.				
2.				
3.				
4.				
5.				
6.				
7.				
8.				
9.				
10.				
11.				
12.				
13.				
14.				
15.				



**MAXEN**  
FIREPLACES

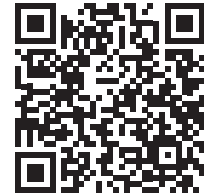

## PRODUCT REGISTRATION

TO ACTIVATE YOUR 15 YEAR WARRANTY, PLEASE COMPLETE AND RETURN WITHIN 30 DAYS OF INSTALLATION TO:

ESCEA LTD  
PO BOX 5277  
DUNEDIN  
NEW ZEALAND

Or complete your product registration online

[www.maxenfireplaces.com/registration](http://www.maxenfireplaces.com/registration)

NAME: \_\_\_\_\_

ADDRESS: \_\_\_\_\_

\_\_\_\_\_

\_\_\_\_\_

EMAIL: \_\_\_\_\_ PHONE: \_\_\_\_\_

MODEL: \_\_\_\_\_

SERIAL NUMBER: \_\_\_\_\_

DATE PURCHASED: \_\_\_\_\_

PURCHASED FROM: \_\_\_\_\_

DATE INSTALLED: \_\_\_\_\_

INSTALLED BY: \_\_\_\_\_